

# USER GUIDE

## ONE PIECE SINGLE-FLUSH TOILET

Model Number: 81170



# TOOLS AND MATERIALS YOU MAY NEED



A. Water Supply Kit



B. Adjustable Wrench



C. Level



D. Tape Measure



E. Putty Knife

# PACKAGE CONTENTS

## One-Piece Toilet



## Wax Ring/Gasket



## Floor Mounting Hardware

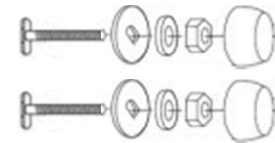

## BEFORE INSTALLATION



Please make sure the following requirements are met.

1. Minimum distance between finished wall and center of the floor drain should be 12".
2. Minimum distance between the center of the shut-off valve to the center of the drain should be 8-1/2" (FIG 1).

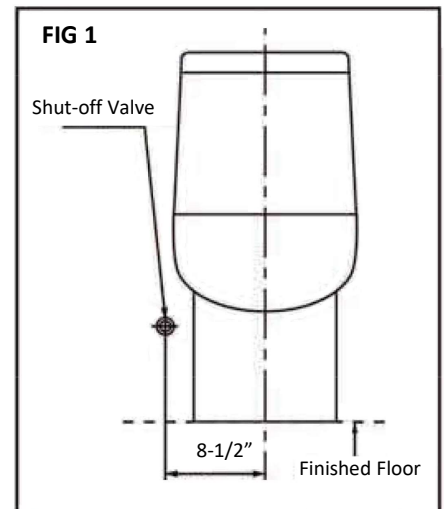

## INSTALLATION

1. Install new floor bolts into floor flange. (FIG 2)

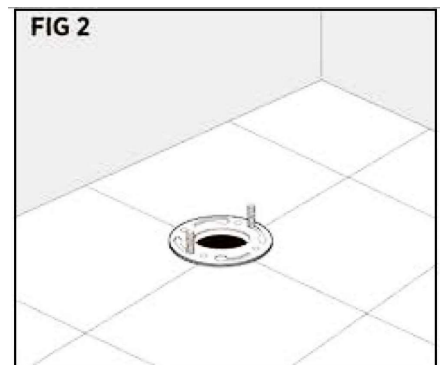

2. Attach flexible water supply line (not included) to the inlet of the fill valve and hand tighten ONLY. **At this point, DO NOT connect to the water shut-off valve. (FIG 3)**

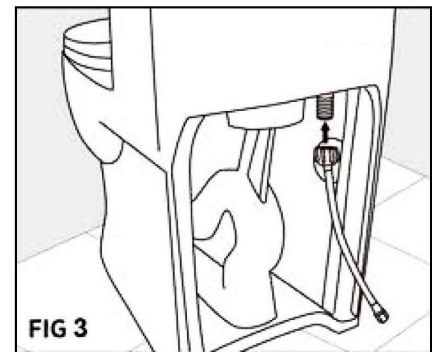

3. Place the new Wax Ring around the waste flange of toilet bowl. (FIG 4)

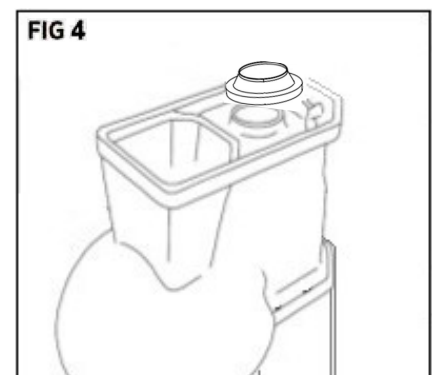

## INSTALLATION (Continue)

4. Lower the toilet onto the closet bolts, so the bolts project through mounting holes in base of toilet. (FIG 5) Using a rocking motion, press the bowl down to position the toilet onto the flange

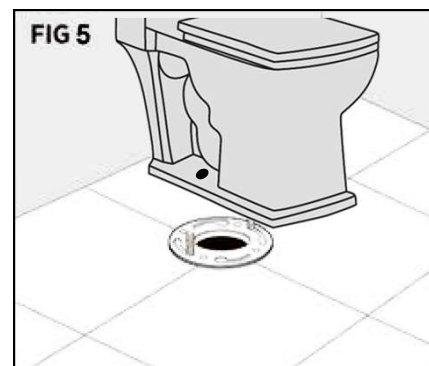

5. Install plastic cap washers, followed by metal washers, nuts and plastic caps onto the closet bolts. (FIG 6) Tighten the bolts alternately until toilet is firmly seated on the floor. **CAUTION: DO NOT OVERTIGHTEN NUTS, SEVERE DAMAGE MAY OCCUR**

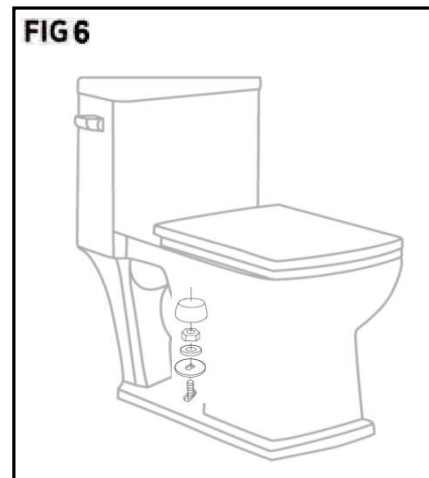

6. Connect the flexible water supply line (not included) to the shut-off valve. Tighten coupling nut securely. (FIG 7)

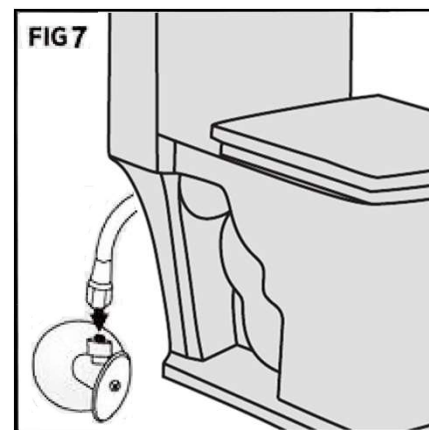

7. Turn on water supply valve and allow tank to fill until float valve rises to shutoff position. Check for leakage at fittings, tighten or correct as needed.

# WARRANTY

## **1-Year Limited Warranty**

**Our products have been manufactured under the highest standards of quality and workmanship. innoci usa warrants to the original purchaser that our products are free from any defects in material and workmanship by normal use for 1 year from the date of purchase. A replacement for any defective part will be supplied FREE OF CHARGE for installation by you.**

**This warranty is valid to the original purchaser only and does not cover product damage due to installation error, product abuse, product misuse, etc. whether or not performed by professionals. innoci usa will not be responsible for labor charges and/or damage incurred in installation, repair or replacement nor for any incidental or consequential damages.**

**All warranty claims should be sent to [customerservice@innoci-usa.com](mailto:customerservice@innoci-usa.com) or call 1.866.479.8076. Our customer service representative will contact you promptly to help you go through the process until you are completely satisfied with our products.**

**SHORTAGE OR DAMAGED PRODUCTS All shipments are carefully inspected and counted before leaving our distribution centers. Please inspect carefully on receipt of merchandise, noting any discrepancy or damage on the carrier's freight bill at that time, and file a claim with the carrier within 10 days from receipt of order. Then contact our office. Deductions from invoices for shortages or damage claims will not be allowed.**

**RETURN NEW GOODS All claims for returns or adjustments must have prior approval and return authorization (RA) number. Only original, sealed product in salable condition are eligible for return. Credit for authorized returns will be issued at the net price paid for the product and subject to a 15% restocking/handling fee. Merchandise is to be returned via prepaid freight. All unauthorized returns will be refused or subject to a 25% restocking/handling fee.**

**To request an "RA" number: Contact our Customer Service Representatives at [customerservice@innoci-usa.com](mailto:customerservice@innoci-usa.com). We will send you a Return Authorization Number (RA) by return email. Please take necessary precautions when returning merchandise to prevent additional damage. Insurance is the responsibility of the shipper.**

**innoci usa, Inc.**

14530 Best Ave,  
Santa Fe Springs, CA 90670

[www.innoci-usa.com](http://www.innoci-usa.com)